

PBSE - SERIES PHOTOCONDUCTOR

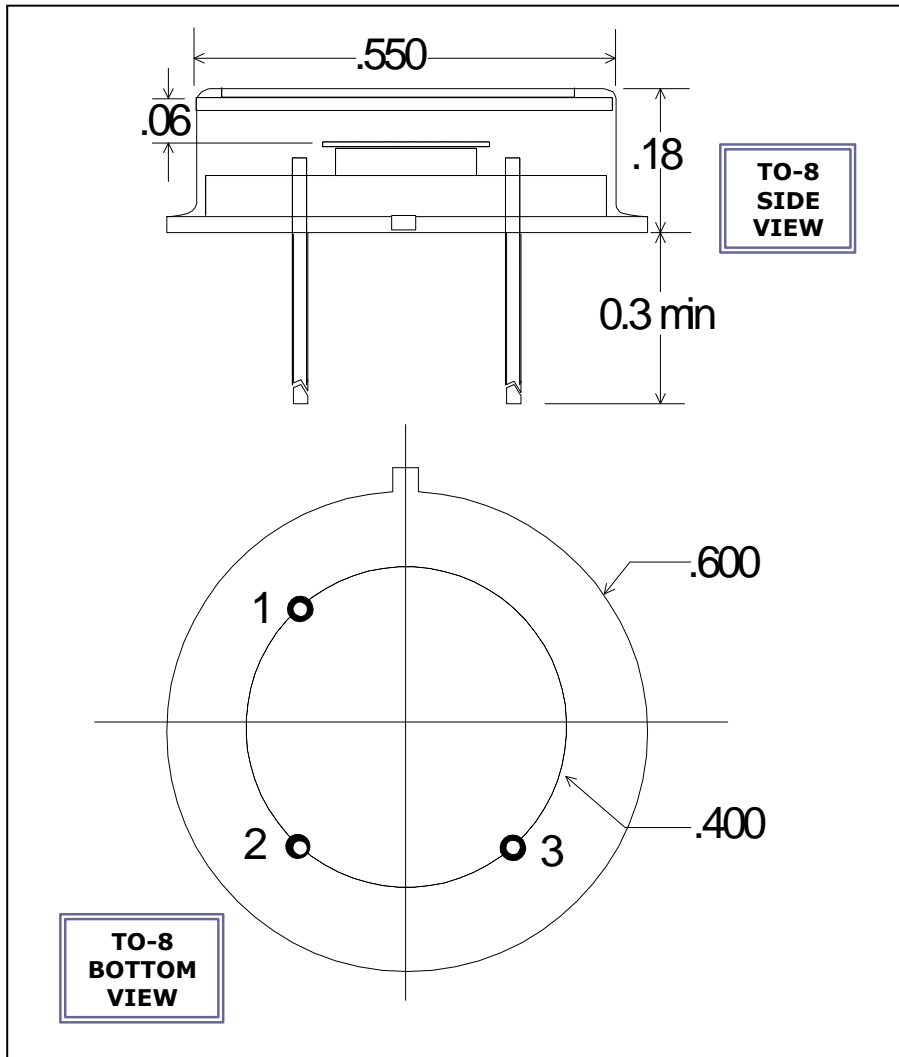

Part No: PBSE - 050

PIN OUT

- 1 = DETECTOR
- 2 = CASE
- 3 = DETECTOR

Note:

Dimensions in millimeters

Application Note

ELECTRO OPTICAL SYSTEMS offers room temperature infrared detectors. The units have state-of-the-art sensitivity and may be supported by accessories such as optical filters (longpass and bandpass), integral preamplifiers, and infrared source assemblies. These units find applications in industrial control systems, gas analyzers, thermal sensors, and general infrared instrumentation.

SPECIFICATIONS

Active Area (mm)	5 x 5
Operating Wavelength (nm)	1 - 4.5
Resistance (MΩ)	0.1 - 1.0
D* (pk, 1000Hz, 1Hz) cm Hz ^{1/2} / W	2 x 10 ⁹
Responsivity (V/W) @ 50V bias	1000